

SYDNEY TRAMWAY MUSEUM

**BERLINER VERKEHRS-BETRIEBE (BVG)
(Berlin Transport Company)**

TZ69/BZ69 TYPE TRAMCARS

Instruction Manual for Car Nos.3007, 5133 & 269 017

Second Edition

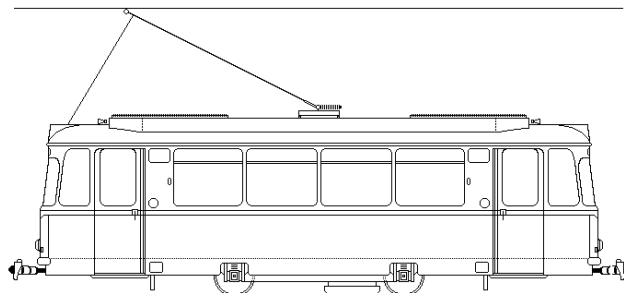

SYDNEY TRAMWAY MUSEUM

First Edition Compiled and Produced by W. M. Denham
published in January 1996.

This Second Edition edited and produced by
W. M. Denham
for the
South Pacific Electric Railway Co-operative Society Limited
PO Box 103, Sutherland, NSW 1499
May 2007

- INDEX -

01	GENERALLY	page 4
02	THE TRAM	4
03	CURRENT COLLECTOR	4
04	DRIVER'S EQUIPMENT	5
05	ELECTRICAL SAFETY	5
06	ROOF LADDER	5
07	CAR LIFTING POCKETS	5
08	SCHARFENBERG COUPLINGS	5
09	TRAILER EMERGENCY BRAKES COUPLING	6
10	LIFEGUARDS	6
11	TRUCKS	7
12	MOTOR GENERATOR SET/BATTERIES	7
13	AUXILIARY POWER/BATTERY SWITCH	7
14	AUTO CIRCUIT BREAKER	7
15	POWER CONTROLLER	7
16	CONTROL PEDALS	8
17	FOOT GONGS AND AIR HORNS	9
18	SERVICE BRAKE	9
19	DYNAMIC AND EMERGENCY BRAKING	9
20	PARKING BRAKE	10
21	SANDING GEAR	10
22	DOORS	10
23	SWITCHES	11
24	DRIVER'S CABIN ACCESS	11
25	DRIVER'S SEAT	12
26	DRIVER'S CABIN LAYOUT	12
27	EXTERNAL EMERGENCY ALARM	12
28	PANEL "B" ("A" AND "B" ENDS)	13
29	DRIVER'S CONTROL DESK	13
30	CONTROL PANELS UNDER DRIVER'S DESK – "A" AND "B" ENDS	14
31	CONTROL PANEL, "A" END VESTIBULE MOTOR CAR	14
32	CONTROL PANEL, "B" END OF TRAILER	15
33	LIGHTS	15
34	HEATERS AND VENTILATION	15
35	WARNING BELL/CONDUCTOR'S SIGNAL	16
36	DESTINATION INDICATORS	16
37	COUPLED OPERATION	16
38	PREPARING TRAM FOR TRAFFIC	17
39	CHANGING ENDS	17
40	COUPLED SET OPERATION - CONDUCTOR' S DUTIES	17
41	STABLING TRAM	18
42	AVAILABILITY FOR SERVICE	18

SYDNEY TRAMWAY MUSEUM

01 GENERALLY

The Berlin (BVG) cars Nos. 3007, 5133 & 269 017 are four-wheel vehicles. The motor trams have direct power control as well as dynamic, track and hand brakes. They are also equipped with a number of auxiliary devices and controls that are sufficiently non-standard to warrant special consideration when compared with most other Museum fleet cars.

Therefore, to avoid damage to the trams, members are directed not to attempt to drive them until they have undergone essential tuition.

02 THE TRAMS

Originally motor cars Nos. 5132 and 5133 and trailer No.2257 of the former East Berlin system they were renumbered as 223 007, 223 008 and 269 017 (respectively then 3007, 3008 and 3717).

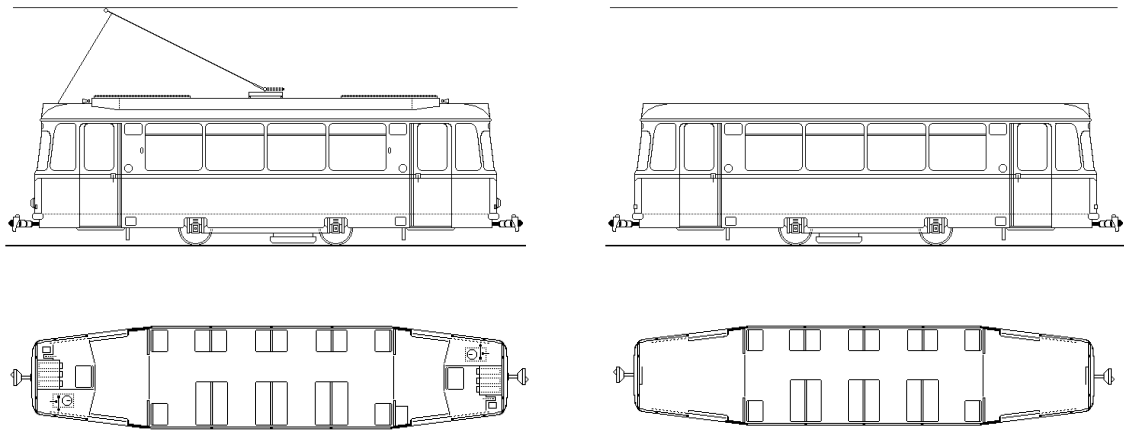

Nos. 3007 and 3008 are double-ended two-motor saloon cars with front and rear egress, protected by electrically operated sliding doors. No. 3717 is a matching saloon trailer car.

In BVG service the No. 1 End of each tramcar was designated the "A" End, the No. 2 End being the "B" End.

03 CURRENT COLLECTOR

A pantograph originally collected traction power. However, until the museum tramway overhead wiring is adjusted, the motor tramcars have been fitted with a single standard trolley pole.

Special rope hooks may be provided at each end of the tramcars to secure the trolley rope when the tram is in operation. Bumpers are fitted to the roof to protect roof mounted control equipment. A pole hook may be fitted on the roof housing to secure the pole when the cars are out of use.

SYDNEY TRAMWAY MUSEUM

04 DRIVER'S EQUIPMENT

The driver will require a reverser key to unlock the power controller. In addition, an auxiliaries switch key must be inserted in the control desk for the head and marker lights to function. Attached to this is a triangular socket key that is used to unlock/lock egress door locks and numerous equipment panels and auxiliary panels internally and externally on the tram.

05 ELECTRICAL SAFETY

The trams have an all-steel body. Therefore, should they run onto non-conducting rails or be badly derailed, all metal parts on the tram should be considered "live" until the trolley poles are removed from the overhead wire.

Because of control equipment that is carried on the roof of the trams, the trolley wire above the tram should be de-energised before any person climbs onto the roof.

06 ROOF LADDER

The motor tramcars are fitted with a folding roof ladder located in the Right Hand door pillar, "A" End, indicated by a handrail from the gutter rail to the roof housing. To open, unlatch this ladder using the triangle key and pull down, using the finger pull below. Ensure the ladder is folded and latched before moving the tram.

07 CAR LIFTING POCKETS

Built into the car sides below floor level at each major door pillar are pockets to receive lifting beams. These are fitted with small latched covers. The driver is to inspect the tram before taking it into traffic and ensure that the covers are latched, and that they remain secured while the tram is in operation.

08 SCHARFENBERG COUPLINGS

These are fitted to allow the cars to be mechanically coupled and they carry electric coupling boxes as well. To operate, centre the couplings on facing tramcars, then drive one car up to the other until the couplings engage and lock. The pivoted electric connector box on each coupling should move upright in contact with that on the adjoining car. This movement will also raise a protective hood out of the way.

If the connector does not come up fully operating a lever on top of the coupling and behind the box may manually raise it. A sleeve on the end of the lever is pulled outward to unlock the lever that is then pushed or pulled into the required direction.

To uncouple the cars, pull up one of the side levers to its full extent, thereby releasing the mechanical coupling. Apply the handbrake on one car and try to drive the other car away a short distance. The mechanical couplings should part. The electric couplings should also part and swing back and the protective cover close over

SYDNEY TRAMWAY MUSEUM

the contacts. ENSURE ALL COUPLED TRAMS ARE SECURED BEFORE RELEASING THE MECHANICAL COUPLING.

In due course a special transition coupling will be provided if the cars have to be coupled to other types of tram. This is to be inserted in the socket of the other tram and then into the Scharfenberg coupler. This coupling must be restored to the brackets on car No.3007 when not in use.

Until this coupling is provided, release the coupling tongue on the Scharfenberg coupler and fit a medium length coupling bar secured by a shackle. Propel the Berlin car with extreme care.

09 TRAILER EMERGENCY BRAKES COUPLING

Suspended under the couplings of the motor tramcars is a rod attached to the car body and free to swivel with the coupling. The free end of the rod terminates in a ring.

Under the trailer couplings there are two rods. One is fixed and finished as on the motor tramcars. The other is connected to the trailer car brake rigging and ends with a short chain and hook.

When a trailer car is coupled to a motorcar the hook on the trailer is fixed into the ring of the adjoining car. (In Berlin, when a second trailer car was attached, the hook in the second trailer was attached to the ring on the first.)

If the main coupling should disengage in traffic and the trailer pull away from the motorcar, the linked emergency brake rods will pull a release rod on the trailer and fully apply the disc brake mechanism on the trailer. As the vehicles part further, a weak link in the chain will open and the emergency couplings will sever.

Once the trailer is secured, pulling out a handgrip may reset the emergency brake. This will be found below the main door pillar on the Left Hand side of the car facing the disengaged coupling.

Any tram on which this emergency procedure has been operated must be carefully returned to the depot and not further used until the equipment has been examined and the weak link restored.

BEFORE the trailer is uncoupled from a motorcar the driver must ENSURE that the emergency coupling is disconnected and that the coupling hook is secured clear of the ground.

10 LIFEGUARDS

The tramcars are fitted with simple operating lifeguards. The light brush fenders at each end of the vehicle should be treated with respect and the tram not be allowed to run into obstructions.

SYDNEY TRAMWAY MUSEUM

11 TRUCKS

The tramcars are of a truckless type and are fitted with two axles with roller bearing axle boxes. The axle boxes are fitted directly to the underframe of the car body. Springing is minimal so caution must be exercised when driving the trams at any speed.

Each motor tramcar axle is fitted with one 80 hp motor, inside axle-hung. When lightly loaded, the tram has a strong tendency to accelerate rapidly which could cause discomfort or even injury to passengers and crew. To avoid wheel slip and jolting the handbrake should be applied at each stop and released gradually after the first notch is struck.

12 MOTOR GENERATOR SET/ BATTERIES

Control power at 24 volts DC is provided by a motor/generator set under the motor tramcar floor. The M/G set is in circuit with a 24-volt battery located under a seat in the passenger saloon. The position of the battery box is marked with an "H" on the window pillar above. Apart from ensuring the panel in the front of the battery box is properly secured there is no reason for traffic staff to interfere with this box or the wet cells within. A battery is also provided in the trailer car.

Failure of the M/G set to operate will require the tram to be returned to the tram shed immediately for changeover. Failure of the battery supply is of nuisance value only but must be reported at the end of an operating shift. Failure of both these sources of power may render the tram inoperable.

13 AUXILIARY POWER/ BATTERY MASTER SWITCH

An auxiliary power master switch is fitted to each tramcar and must be switched ON for the tram to operate and OFF after stabling the tram to prevent the batteries being drained.

The master switch for the motorcar is located on the "A" end control desk, front right hand side and on the trailer car is located behind a removable panel at the "B" end. The trailer battery supply must be switched OFF after stabling the tram otherwise a warning bell will ring after the motor/generator set in the motor tram is switched off.

14 AUTO CIRCUIT BREAKER

An automatic circuit breaker is located in the ceiling above each driver's seat. It may be manually opened or closed, or reset, by turning the handle projecting below the ceiling fully to the OPEN (*Aus*) or CLOSED (*Ein*) position. Both auto breakers must be closed for the tramcar to operate.

15 POWER CONTROLLER

The motor tramcars are fitted to run on 600 V DC, direct control, non-coupling. They are driven by means of a combination power/dynamic brake

SYDNEY TRAMWAY MUSEUM

controller at either end. This controller has 2 definite Series power notches (First and Full Series) and 1 definite Parallel power notch (Full Parallel) for normal acceleration, with a mechanical stop at Full Parallel.

The power/brake controller is built into the desk to the left of the driver. It is provided with an operating handle that works clockwise to apply power and anticlockwise to shut off power and apply the dynamic brake. The control handle is geared to a pointer beside the handle that rotates in the opposite direction to indicate the power setting. A ratchet/lock device is fitted against the power handle for the purpose of restricting movement of the handle if either motor is cut out.

A reverser key is required to unlock the controller. This is inserted on the reverser drum in the normal manner with the key pointing away from the driver. There are five positions of the reverser barrel: -

NEUTRAL: where the key may be inserted or removed;

CLOCKWISE: **REVERSE**;

(One step only, to **I+II**)

ANTI-CLOCKWISE (from Neutral): **FORWARD**;

(First step - to **I+II**) both motors in circuit;

(Second step - to **I**) motor No.2 cut out;

(Third step - to **II**) motor No.1 cut out.

When the reverser key is moved to the "forward" position it will encounter a mechanical stop. To move it further, to the motor cut-out positions, it will be necessary to lift the handle as far as it will go then push it to the second step or third step as required. To return the reverser to OFF the key must be returned to the "forward" position and then allowed to drop fully onto the reverser shaft after which it may be turned to OFF and, if necessary, removed.

When the reverser is set to either of the single motor positions, the controller cannot be operated into the Parallel notches, forward. It will be seen from this that it is not possible to drive the tram in reverse on one motor alone. To reverse the direction requires the driver to proceed to the other end of the tram and drive from that end - forward - with the respective motor cut out.

There is no stop block for OFF since the controller can be rotated beyond OFF towards 11 braking notches. Some latitude is available between the first power notch and the first brake notch, but the controller handle must be in the OFF position before the reverser handle can be removed.

16 CONTROL PEDALS

Control pedals are located on the floor forward of the driver's seat and provide for the following functions: -

LEFT PEDAL: applies sand to the rail forward of the leading wheels. Resting one's foot on the pedal at any time will usually result in sand being dropped and could lead to rapid exhausting of the supply.

SYDNEY TRAMWAY MUSEUM

CENTRE PEDAL: operates the electro-magnetic track brake on the tram including coupled cars.

RIGHT PEDAL: operates the electric foot gong.

17 FOOT GONGS AND AIR HORNS

The motor tramcars are fitted with electrically operated foot gongs worked from a pedal in the driver's cab. The gong sounds only at the end of the tramcar where the pedal is worked.

In due course the motorcars will be fitted with electrically operated self-contained air horns that sound on the driving end only of the tramcar. They will be operated by a push button on the driver's control desk that was formerly used for cancelling the emergency signal (*Löschen*).

18 SERVICE BRAKE

The tram is controlled through the dynamic braking notches on the power controller or by the manual hand brake acting directly on brake drums fitted to both traction motors on the tramcar being driven. The effect of the dynamic brake is transmitted to the trailing cars through the electric couplings into a magnetic brake cylinder on the trailer car.

19 DYNAMIC AND EMERGENCY BRAKING

The tram is fitted with a regulated dynamic brake that is brought into operation by working the power/brake controller anti-clockwise from OFF through the 11 braking notches. This is done in stages, notch-by-notch, until sufficient braking effect is obtained. The dynamic brake may be eased as necessary. The reverser should remain set for the direction the tram is moving during operation of this brake.

Initially, the dynamic brake function takes a significant time to build up so when the tram is coasting towards a known stopping place the controller should be placed in the first braking notch. This will allow the dynamic function to generate but will usually not create a noticeable braking effect. When necessary, the controller may be moved to the second and subsequent braking notches when the effect will then be virtually instantaneous.

The dynamic brake may be eased as required (i.e. "back-notched") without detriment to the equipment.

Second and Third Emergency braking procedures are also available if required.

It should be noted, however, that the effect of the dynamic brake and the Third (Electrical) Emergency brake are lost when the tram speed reduces to about 7 km/h (walking pace).

SYDNEY TRAMWAY MUSEUM

If, in an emergency situation, the tram begins to roll away backwards, the reverser handle should be left in the "Forward" position, the dynamic brake will function regardless of the direction setting of the reverser.

Reduced dynamic braking is available with either motor cut out.

The tramcars are also fitted with electro-magnetic track brakes that operate on each car from the control pedal at the driving position. Pressing this pedal will cause the brake slippers to energise and drop onto the rail causing a rapid and severe brake application.

Because of the number of raised checkrails on the system, drivers are directed to pass these locations at reduced speed to ensure that the track brake slipper can rise over the obstruction.

20 PARKING BRAKE

MOTOR CARS: These are fitted with a band brake on each motor and operated together on each car by a hand brake lever from either end of the car.

TRAILER CAR: This is fitted with a disc brake operated by a lever with fold out handle from either end of the car. A foot pedal near the floor below the brake lever releases the lever.

Except when parked on level track, the tram must be chocked when not under the immediate control of the Driver.

21 SANDING GEAR

The motor tramcars are fitted with sanding gear that delivers sand under the front wheels by pressure on a pedal at the driver's position. Sand boxes are located under the corner seats in the saloon. A visual indicator is fitted in the side of each sand box to show the approximate amount of sand in the box.

22 DOORS

Sliding doors are fitted to each egress. The driver closes the doors electrically. Before the tram moves off but after all doors are closed, indicated by a three-lamp indicator on the Driver's Control Panel being extinguished, the driver should press the release button (*Türen frei*). If this is not done the door motors will remain in circuit and prevent doors from being manually opened.

On reaching a stop the doors are unlatched, but do not open, and must be slid open by hand. Because passengers may not be familiar with this procedure, Traffic Staff are to be on the alert and direct passengers to perform this manual opening task when necessary.

The doors are not interlocked with the controls and the tram may be operated with doors opened or closed. However, it should be noted that the doors might roll

SYDNEY TRAMWAY MUSEUM

open and closed unexpectedly as the tram progresses if they are not shut. Closing the doors electrically also latches the doors.

Although doors may be opened on either side of the tramcar once they are unlatched, the "door close" push button activates warning bells and lamps on one side only of the car. A switch is provided on the driver's control desk to alter the closing signals between sides of the tram.

On the pillar inside the car beside each door is a switch that overrides the door control. Pressed in at the top it disconnects that door from the "close" circuit, pressed in at the bottom the door is reconnected to the "close" circuit.

If a door has been isolated and opened and the "door close" button is pushed then the door will close immediately the override switch is closed.

Doors are fitted with a mechanical lock that may be worked from inside or outside the car with the triangle key provided. All doors should be closed and locked when the trams are left stabled out of the tram shed outside of traffic hours.

23 SWITCHES

Generally any of six types of electric switch may be found on the Berlin cars.

TRACTION POWER AUTO SWITCH: located above the driver's seat and set (or reset) by turning the large black handle to ON (*Ein*) or OFF (*Aus*).

ROTARY SNAP SWITCH: turned to OFF (*Aus/O*) and to ON (*Ein/I*).

THREE POSITION ROTARY SWITCH: Centre OFF (*Aus*), pointer to the left "Normal", to the right "Reverse".

ROCKER SWITCH: Top in - "Reverse"; bottom in - "Normal".

TUMBLER SWITCH: in the European manner, DOWN (OFF), UP (ON).

PUSH BUTTON: Press briefly (2 seconds) and release. If pressed and a click is noted, then usually it will be necessary to press the button once more to reset the function.

24 DRIVER'S CABIN ACCESS

The driver's cabins are provided with a narrow entry door on two way spring hinges. In warm weather the door may be latched back against the side of the tram. A second hinged panel (door) is provided behind the driver's seat that may be unlatched, if required, for additional ventilation. When this panel is closed, a drop down pane at the top may be opened.

Several tools for track maintenance, etc are carried on the inside face of this door at the "B" End and crews are to be on the alert for passengers attempting to interfere with this equipment if the panel is opened.

SYDNEY TRAMWAY MUSEUM

25 DRIVER'S SEAT

The driver's seat is adjustable. A knob on the right hand side frame near the front must be depressed to allow the seat to move fore and aft and must be properly inserted to hold the seat secure. A similar knob near the seat back allows the seat back tilt to be adjusted. A large knob on the seat support allows the seat to be raised or lowered.

Because of the short route distances involved it is recommended that the seat adjustment, as found, not be altered unless absolutely necessary, especially if several drivers will be operating the tramcar during any day shift.

26 DRIVER'S CABIN LAYOUT

Figure 1

("A" and "B" Ends unless otherwise noted.)

- A: Sliding door pocket.
- B: Switch Panel "B".
- C: Battery control switch, "A" End only.
- D: Handbrake.
- E: Footgong pedal (under control desk).
- F: Magnetic track brake pedal (under control desk).
- G: Sand pedal (under control desk).
- H: Main control desk.
- J: Power controller: -
 - a: reverser;
 - b: power handle;
 - c: pointer.
- K: Driver's seat.
- L: Driver's door.
- M: Main switch, over Driver's seat.
- N: Hinged panel behind Driver's seat.
- P: Emergency alarm push button.
- Q: Emergency alarm cancel push button.
- R: (Under panel) switch and light to illuminate 24 V fuse panel.

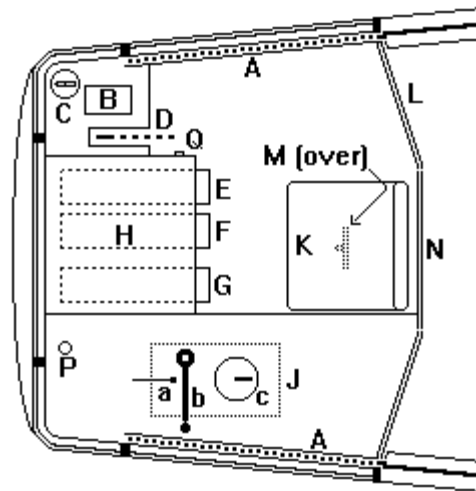

Figure 3

27. EXTERNAL EMERGENCY ALARM

Pressing the push button forward of the power controller ("P", Fig 1) activates an emergency alarm system that causes the external turn lights to flash and an alarm to sound. It is cancelled by pressing the pushbutton ("Q", Fig.1) on the right hand edge of the Driver's Control Desk ("H", Fig.1). It would generally only be activated as a security alarm.

SYDNEY TRAMWAY MUSEUM

28 PANEL "B" ("A" and "B" Ends)

Figure 2

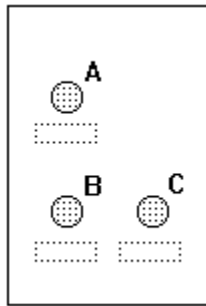

- A: Heater relay OFF (*Heizung aus*)
- B: Auto points controller - not in use (*Weichenverstellung*)
- C: Headlight dimmer [see "Driver's control desk: J"] (*Abblendschalter*)

Figure 2

29 DRIVER'S CONTROL DESK

Figure 3

- A: Window demister, where fitted (*Klarsichtscheibe*)
- B: Rear view mirror demister, where fitted (*Spiegelheizung*)
- C: Emergency saloon lights, on all coupled cars (*Notlicht*)
- D: Trailer back-up signal (*Rangieren OS - Betrieb*). Sounds a buzzer in rear of motorcar when held down. Exact function still to be determined.
- E: Driver's cabin light (*Fahrerraum*)
- F: Emergency flashers, on motor car and trailer car only, pull UP to activate, push DOWN to cancel (*Warnblinklicht*)
- G: Emergency lights (C) indicator lamp (*Notlicht*)
- H: Driver's window wiper (*Wischer*)
- J: Headlight indicator, glows when headlight on "high beam" (*Scheinwerfer*)
- K: Emergency indicator, glows when emergency push button operates (with siren) on trailing car (*Ladeleuchte*)
- L: Door warning control switch (*Warnanlage*) Up: door closing warning lights and bells operate on Left Hand Side of tram only; Down: door closing warning lights and bells operate on Right Hand Side of tram only
- M: Turn indicator lamp (*Blinkeleuchte Triebwagen*)
- N: Back-up signal indicator lamp (*Rückwärts-signal*). Exact function still to be determined.
- P: Doors unlatched button (*Türen frei*)
- Q: Horn button. Formerly emergency alarm cancel (*Löschen*)
- R: Door close button (*Warnen*)
- S: Battery charge meter
- T: Control panel lights switch. Key out, head and marker lights OFF; key fully in and at position '1' tail lights ON motor tram and trailer only, at position '2' head light ON motor tram only and tail lights ON motor tram and trailer.
- U: Equipment removed.

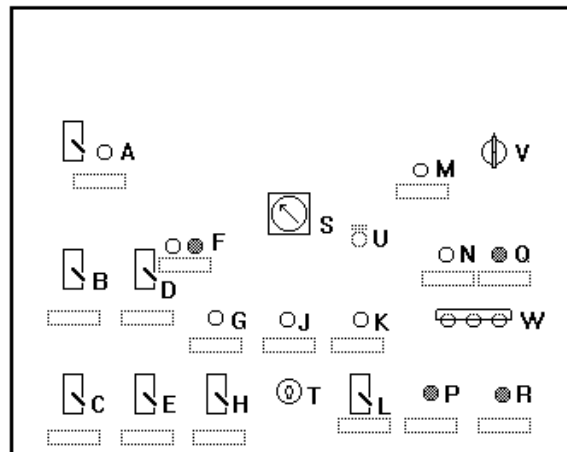

Figure 3

SYDNEY TRAMWAY MUSEUM

- V: Turn signal switch: Normal (to the left) - right turn; Reverse (to the right) - left turn.
 W: Door indicator lights; glow when doors are open.

30 CONTROL PANELS UNDER DRIVER'S DESK

"A" End Figure 4

- A: Trailer car saloon lights (*Licht bw*)
 B: 24 V control advice notice (*Steuerung 24v*)
 C: Driver's cabin heating (*Heizung fahrerstand*)
 D: Motor/generator (*Umformer*)
 E: fuses, behind swing out panel
 F: Heaters in trailer car; car saloon lights glow when heaters turned ON; possibly as visual warning (*Heizung bw*)
 G: Saloon heating (*Heizung*)
 H: Saloon lights, motor tram (*Beteuchtung*)

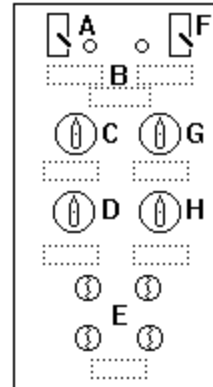
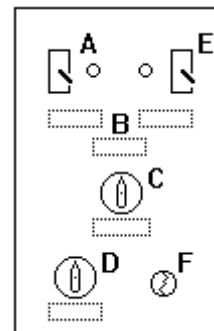

Figure 4

"B" End Figure 5

- A: Trailer car saloon lights (*Licht bw*)
 B: 24 V control advice notice (*Steuerung 24v*)
 C: Driver's cabin heating (*Heizung fahrerstand*)
 D: Motor/generator (*Umformer*)
 E: Heaters in trailer car; car saloon lights glow when turned ON; possibly as visual warning (*Heizung bw*)
 F fuse



heaters

Figure 5

31 CONTROL PANEL "A" End VESTIBULE MOTOR CAR Figure 6

- A: 600 V fuse
 B: 24 V fuse
 C: Voltage regulator

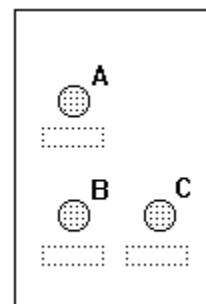

Figure 6

SYDNEY TRAMWAY MUSEUM

32 CONTROL PANEL, "B" END OF TRAILER *Figure 7*

- A: 600 volt fuse
- B: Battery fuse (*Batterie*)
- C: Battery switch (*Batteriehaupt-schalter*)
- D: Emergency lights (*Notlicht*)
- E: Tail lights (*Außenlicht*)
- F: 24 volt fuse

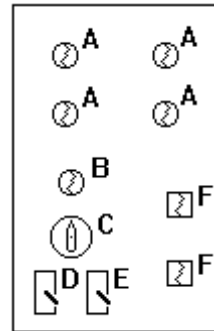

Figure 7

33 LIGHTS

Saloon Lights: Motor car and Trailer car: operated from control panel under Driver's desk "A" End.

Saloon Emergency Lights: Switch on Driver's control desk.

Driver's Cabin Lights: Switch on Driver's control desk.

Doorway Courtesy Lights: Will glow when doors open and control panel lock key is fully inserted and turned to '1' or '2'.

Head Light: On leading motorcar will glow when control panel lights key is fully inserted and turned to '2'. Headlight dimmer is operated from switch on Driver's control desk.

Tail Lights: Fixed marker lights on rear of front motor car and on trailer car will glow when control panel lights key is fully inserted and turned to '1' or '2'.

Stop Lights: Stop lights on rear of front motorcar and on trailer car will glow when power controller is operated into any braking notch.

Turn Indicator/Emergency Flashers: Turn indicators will flash on side, front and rear of leading motor tramcar and on front and rear of trailer car when switch on Driver's control desk is operated. Emergency flashers will operate on both sides of tramcars when push button is released on Driver's control desk.

(NOTE: not all electrical functions will operate through to the trailing motorcar.)

Destination Box Lights: Will glow when car lights are turned on.

34 HEATERS AND VENTILATION

Since the tramcars were designed for use in a relatively cold climate they are rather poorly equipped with fresh air ventilation. On the other hand, electric heating elements are provided under most of the saloon seats and may also be fitted to the front windows and side view mirrors.

SYDNEY TRAMWAY MUSEUM

Because of the milder climate in Sydney it is unlikely that the heaters will require more than occasional use. Should the tram become exceptionally hot inside, the crews should examine the heating controls to see that they have not been turned on.

Bottom hung quarter light windows are provided along each saloon that may be unlatched and allowed to open into the car onto stays. If necessary the stays fold flat allowing the hinged sashes to drop down further.

The top panel of the driver's cabin centre door can be unlatched to fold down flat onto the panel. The glazed panels at each end of the trailer in place of the destination box are top hung and hinge outwards.

35 WARNING BELL/ CONDUCTOR'S SIGNAL

An emergency warning bell operated by push buttons in the motorcars and the trailer car were provided for use in Berlin where the trams were run without conductor supervision. As this form of operation is not permitted on the Museum tramway under the terms of the Society's Rail Safety Act Accreditation, the locking device on the warning system has been disabled allowing the warning system to function as a conductor's signal.

36 DESTINATION INDICATORS

A roller blind is fitted into the roof above the driver's window at each end of the motor trams. This is internally illuminated. To operate, pull or push the operating handle to engage the gear drive and turn in a clockwise direction.

A route number board holder is built into the roof at each end of each car and number boards will be provided to fit these recesses.

Route description board/route number board holders are also provided on the side of the tram adjacent to the egress doors. Special boards will also be provided for use in these recesses.

Internally, above the windows on each side of the saloon, are clips to support route information boards.

37 COUPLED OPERATION

The tramcars are not equipped for direct control or multiple unit coupled operation. NOTE: When coupled motorcars are operated, a brakeman must be present in the trailing car since the dynamic brake does not function on the trailing motor tramcar.

Subject to approval coupled set trailer operation of the Berlin cars may be undertaken as follows: -

SYDNEY TRAMWAY MUSEUM

3007 + 5133: to be run as a motor/trailer set with the driver changing tramcars at turn back points and termini, the trailing car being towed dead in each direction. The trolley pole may require to be raised on the trailing car for auxiliary power.

3007 + 269 017 + 5133: to be run as a motor/trailer/trailer set with No.269 017 marshalled between the two motor tramcars, the driver changing motor tramcars at turn back points and termini, the trailing motor car being towed dead in each direction. The trolley pole may require to be raised on the trailing motorcar for auxiliary power.

The preferred method of operation of three cars is that one motorcar will tow the trailer out, followed by the other motorcar, under convoy operation with Staff and Ticket. At a terminus or turn-back point the trailer will be exchanged between the two motorcars so that a motorcar is always leading whenever the tram is carrying passengers.

If operations are disrupted, and it becomes necessary to propel the trailer car, all passengers must be requested to alight from the trailer and it must only be propelled for the minimum possible distance and at speeds not exceeding Full Series.

38 PREPARING TRAM FOR TRAFFIC

Examine the tram for possible clearance problems with rear view mirrors. Unlock all car egress doors using the special triangular tube key to allow entry to the car.

Ensure that the handbrake at the driving end is firmly applied and all other handbrakes on the tram are released. Place trolley pole(s) on the overhead wire and ensure motor/generator is operating. Close/operate any control switches necessary to drive the tram including battery switches on motorcars and trailer car.

39 CHANGING ENDS

On arrival at a terminus or turn back point the tram must be stopped, and secured on the handbrake. The driver will then proceed to the other end of the tram and apply the hand brake at the new leading end before signalling for release of the brake at the former driving end.

40 COUPLED SET OPERATION - CONDUCTORS' DUTIES

When coupled set operation is being undertaken the Conductor-in-charge will travel in the rear most car. Prior to giving any proceed signal, all conductors will move to an egress door on the side where passengers are boarding or alighting, open that door and operate the door isolating switch. The assistant conductors will give a hand signal to the Conductor-in-charge, from the roadway if necessary, then step back into the tram and close the isolating switch. The Conductor-in-charge will continue to observe the outside of the tram until giving the "Proceed" signal. The Conductor-in-charge will step into the tram and close the isolating switch.

SYDNEY TRAMWAY MUSEUM

41 STABLING TRAM

When stabling the Berlin cars in the tram shed, and having observed any special instructions mentioned elsewhere, the driver will close all doors and windows, press the "Door Open" button, open all switches so designated, operate the auxiliary power/battery switches to OFF and leave the car by any door which may then be opened manually.

After leaving the car, manually close the door. Remove trolley pole(s) from the overhead wire.

Where directed, lock all doors with the key provided, taking care to ensure all persons have left the car before locking the doors.

When stabling the tram outside the shed and not under direct supervision of a driver, place a chock under the outer wheel on the down hill end of the tram and close all doors. Remove trolley pole(s) from the overhead wire if the tram is to be left for a long period and set the battery switches to OFF.

42 AVAILABILITY FOR SERVICE

BVG cars Nos.3007, 5133 and 269 017 are only to be run by authorised members, specifically trained in the operation of the tramcars. Subject to an accreditation certificate being provided for the cars, they are available for limited use on the Park extension. Although built for "one man" operation, the tram must always carry a driver on the front car and a conductor on each car carrying passengers. Cars in a coupled set not provided with a conductor must have all egress doors locked and not be carrying passengers, to satisfy the safety requirements of the RSA accreditation, until further notice.

SYDNEY TRAMWAY MUSEUM

NOTES:

CAR DETAILS

Classification:

TZ69 (motor cars), BZ69 (trailer car)

("69" = year of manufacture; "T" = *Triebwagen* [motor tram]; "B" = *Beiwagen* [trailer]; "Z" = *Zweirichtung* [bi-directional/double ended]).

Also known as "*Rekowagen*" ["rebuilt car"]; "*Kaffeemuhlen*" [Coffee Grinders]

Built by RAW ("*Reichsbahnausbesserungs-werke Schöneweide*"), the State railway repair workshops at Schöneweide, Berlin as:

Nos. 5132 and 5133, and 2257

Renumbered

1971: 223 007 and 008, and 269 017

1992: 3007 and 3008, and 3717

Entered service:

3007 - 10th November 1969

3008 - 11th November 1969

3717 - 23rd October 1969

Motors:

Nos. 3007, 3008: 2 x 80 hp, per car

Length (over car):

10 720 mm

Length (over bumpers):

11 840 mm

Weight:	No. 3007:	13 500 kg
	No. 3008:	13 300 kg
	No. 3717:	9 600 kg

Officially withdrawn from service on 3rd June 1996 but trailer may have been stored for some months before this.

Handed over 4th August 1996 in Berlin.

To Hamburg, sailed on *Contship Barcelona* on 23rd August, arrived Port Botany on 14th October 1996.

Delivered to Loftus on 21st October 1996.