

---

# **SYDNEY TRAMWAY MUSEUM**

LUBRICATION MANUAL

DECEMBER 2006



# SYDNEY TRAMWAY MUSEUM

## 1. Purpose

To explain the processes and procedures necessary when lubricating tram cars at STM.

## 2. Scope

This procedure applies to the all of the trams operating at the STM.

## 3. Responsibilities

The maintenance staff at STM must follow the processes in this manual.

## 4. References

The original document was compiled by member Robert C Harvey.

## 5. Definitions

STM Sydney Tramway Museum: the trading name of South Pacific Electric Railway Co-Operative Society Limited for tram activities, therefore references to STM.

Lbs Imperial pounds weight

## 6. Lubrication

### 6.1 General.

The bearings in out tramcars have been many years of faithful service and are no longer at the design tolerances of when they were put into service or just overhauled. Therefore until the tramcar is overhauled and bearing tolerances are returned to design limits it may be necessary to increase lubrication rates depending on service requirements. Exceptionally bad bearings should, as soon as possible, be repaired or renewed to save wasting oil, through excessive oil leakage.

Since the bearings on most of the STM trams are apt to be less tight than they should be, and since they would be extremely difficult to replace, it is recommended that the lubrication should be more frequently performed than that which would be the norm in regular tramway service. For trams in regular service, a weekly lubrication all over should be sufficient, except where there is an especially bad bearing.

Hot bearings are due, to a large extent, to poor lubrication, or to an inferior grade of lubricant. Too much lubricant is just as bad as too little, so only the recommended quantities should be used.

Bearings should not be allowed to wear too much as it will cause armature rub or excessive oil leakage. If bearings are allowed to wear to beyond design limits other problems can be caused such as the armature rubbing into the field coils pole faces or wheels wearing into truck frames due to excessive latitudinal wear or excessive oil usage.

# SYDNEY TRAMWAY MUSEUM

It is recommended that the tramcars in regular Museum operation be inspected at least once a month, and at this inspection the tramcar be lubricated.

Since most of our operation is done in warm weather, only summer lubrication practices will be considered.

## **6.2 Lubricant Specifications.**

### **6.2.1 Compressor Oil**

This oil is red or honey in colour when held up to the light. It has a medium flash point and medium viscosity for the summer grade. Low in carbon, it will not “gum” and does not contain lead.

The specific properties of the Summer grade are:

Specific gravity	0.913
Flash Point	188° C (370° F)
Viscosity at 54° C (130° F)	155 seconds
Viscosity at 99° C (210° F)	53 seconds
Ash	None
Acidity	0.05
Cold or pour test	minus18 to minus16° C (0° to plus 3° F)
Lead	None

Galena compressor oil is strongly recommended by Westinghouse.  
Esse No. 1509 compressor oil is used by some roads.

The current oil in use for reciprocating type compressors in use on the Museum tramcars is Shell Corena Oil P grade 68. The oil has a naphthenic base with Shell additives which give it a low carbon deposit formation and exceptional oxidation stability. Shell, in their literature, suggest that the life of the oil is up to 8000 hours before need to change it.

The typical characteristics of Corena are:

Viscosity at 40° C cSt	68
Viscosity at 100° C cSt	8.1
Viscosity index	80
Pour Point	-27° C
Demulsibility	10 (times to 40, 40, 0 mins)
Oxidation Stability	POT Test
Expansion Loss %	11.8 Residue %
Conradson Carbon	1.4

### **6.2.2 Electric Tram Oil**

This oil is brown in colour when held up to the light. It is a compound oil, carrying a percentage of lead compounds dissolved in the oil. It is made especially for use in saturated waste, which means that the waste is able to raise the oil by capillary action. It has a high flash test, high viscosity and fairly cold test, and comes in two grades; winter and summer. It is recommended that the museum only use the Summer grade, as the winter grade is too thin and will run out of the bearings.

It is interesting to note that a small percentage of lead is present in motor car engine oil. This lead soap fills up all of the small valleys in a journal and produces a real smooth surface for the oil to lubricate.

The specific properties of this grade of the Summer grade are:

## SYDNEY TRAMWAY MUSEUM

Specific gravity at 15.5° C (60° F)	0.927
Flask Point	152 deg C (305° F)
Viscosity at 54° C (130° F)	270 seconds
Viscosity at 99° C (210° F)	70 seconds
Ash	0.70
Acidity	0.47
Cold or pour test	minus 15° C (plus 5° F)
Lead	0.58

One recommended lubricant of this type is CALTEX JOURNALTEX or Gulf semi fluid No. 1500 which can be used all year round. This type is used by the Hudson & Manhattan Railroad.

### **6.2.3 Tramcar Bearing Oil**

The current oil in use for the axle bearings and the traction motor armature and suspension bearings which are of the plain bearing design in use on the Museum tramcars is Mobil Mobilgear 634 or Shell Omala Oil grade 460 or ISO VG460. This oil is a lead free extreme pressure gear with additives for anti-corrosion, anti-oxidation and anti-foaming. The main characteristic that concerns the Museum is that this type of oil has a good load carrying capacity thereby ensuring low wear under load.

The typical characteristics are:

Density @ 15° C kg/L	0.886
Flash Point Closed	276° C
Pour Point	-15° C
Viscosity at 40° C cSt	460
Viscosity at 100° C cSt	31.0
Viscosity index	99

### **6.2.4 General Purpose Grease**

For general lubrication, such as centre castings, brake rigging pins, rubbing pads and roller bearings, a grease equivalent to Shell Alvania EP Grease 2 is generally used. It is a grease that has outstanding load carrying capacity through a temperature range of -15° C to 90° C, shows a high mechanical stability and is easily used in grease guns. Also it resists water washout by immersion or spray and is of a lithium base.

The typical characteristics are:

Work Penetration at 25° C	280
Viscosity Mineral Oil at 100° C cSt	14.5
Drop Point	184° C
Timken OK Value	21 kg

### **6.2.5 Gear Case Grease**

This grease is specifically designed for high pressure situations as that which found between the teeth of the pinion gear and the pinion wheel is required to minimise the friction of the grinding action of the gear teeth. The grease that the Museum uses is manufactured by Caltex and is their product 'TMGL'. This grease is semi-fluid, smooth, black, adhesive, high film-strength lubricant specially designed to lubricate the traction motor drive gears, it reduces the friction and the wear of the gears. The normal colour of this grease is black and comes in plastic satchels that are emptied in the gear cases and onto the gears.

# SYDNEY TRAMWAY MUSEUM

The typical characteristics are:

Base Fluid, Viscosity Kinematic at 100° C cSt	367
Four Ball EP Test	
Load Wear Index	53 kg
Weld Point	315 kg
Lithium Soap, mass %	1.5
Timken OK Value	18 kg

## **6.2.6 Double O Grease**

This grease is light straw in colour when held up to the light. It has a heavy viscosity, high flash point, non evaporating, but does not gum. This grease is really a solidified oil, but has a low cold test for a grease. It is a neutral oil with no acidity.

## **6.2.7 Perfection Compound**

This grease is black in colour and looks very much like tar. This grease is specially prepared for gears and pinions and is used in two grades, winter and summer. This grease sticks to the teeth of the gears and covers the teeth to reduce friction and wear. The recommended products are CALTEX EP1, Texaco Crater No. 1 and Gulf Semi-fluid No. 1509.

## **6.2.8 Centre Plate Grease**

This grease is Dark brown in colour when held up to the light. The grease carries a large percentage of lead and heavy oil. It is used for greasing truck side bearings and some centre bearings. In the winter, it is sometimes necessary to thin out the grease. The recommended product is CALTEX EP1.

## **6.2.9 Petroleum Jelly**

This grease is Dark for use in electrical equipment for the protection of sliding or mating contacts.

## **6.2.10 Graphite Based Grease**

This is a grease with graphite base to be used in roller type trolley pole bases where an electrical current is passing through. A normal grease used in this situation would carbonise and not provide any lubrication properties. Graphite grease is and has been used from several different manufacturers, all found to be satisfactory for this use.

# **7. Waste**

## **7.1 Waste Packing Process.**

There is perhaps no other material used in the railway industry that varies so in quality and grade as waste used for packaging bearings. Great care must be exercised in the selection of waste because of the troubles encountered with poor waste.

*Pure Wool Waste* is unquestionably the safest and best material used in packing boxes. Its most important property is that it remains springy and elastic after being soaked in oil. This prevents the packing from backing away from the journal. Another property of wool waste is that it parts with the oil readily.

Wool waste should be composed of pure wool yarn with a few short strands as possible. The short strands should not be less than 300mm (12 inches) long. The strands should be examined to see that

## SYDNEY TRAMWAY MUSEUM

the fibres in the strands are long. The strands should be from about 1 mm (*1/32 inch*) to 2 mm (*1/16 inch*) in diameter. The twist should be fairly loose. In the past, a large hard twisted strand was used which contained too much shoddy material. With large strands, hard twisted, it is easy for waste distributors to work in such materials, as horse hair, cotton and asbestos which are unfit for packing. These unfit materials cause trouble when placed before the window of a bearing. Waste must be free from dirt and moisture.

Cotton is frequently placed in waste strands to help the waste absorb oil, but it glazes when in contact with a journal. Cotton can be detected by burning the end of a strand. Burned cotton leaves a very soft white ash and seems to hold heat pretty well. Wool, on the other hand, does not continue to burn and leaves a hard, black ash. Horse hair and asbestos are used to make a dead material appear lively but trouble is encountered at the window of the bearing.

When a bearing is correctly packed with a good grade of long strand wool waste and the oil level is kept within the correct limits, and reasonable care is taken to exclude dirt and moisture, the useful life of a bearing is greatly extended. The mileage of railway motor bearings has been found to vary from 80 kms to 400 kms (*50,000 miles to 250,000 miles*). Some of this difference is due to the type of service, but most of it is due to variations in lubrication practices.

Since wool waste is the only material that can be successfully used in a bearing box, it is important that its poor capillary properties be offset by using long strands free from impurities.

The amount of waste in a box is just as important as the quality, for the oil feed varies according to the amount of waste that a box will hold, and the amount of waste that touches the journal, e.g. if one strand of waste is in the box and this one strand touches the journal at the window we can expect a certain amount of oil to get to the bearing. If two strands are now placed so as to touch the journal, it is reasonable to expect that twice as much oil can be supplied to the bearing. With this in mind, anything short of a full window of waste will cut down the oil supply which is another point often overlooked.

Another point to remember about waste is the time required for waste to raise oil a given distance. If the oil levels are low in a bearing, it may be necessary to pour oil on top of the waste so that the oil will feed downward, to prevent to hot bearing. ***THIS PRACTICE SHOULD NOT BE RESORTED TO EXCEPT IN CASES WHERE THE OIL LEVELS ARE EXTREMELY LOW. OIL SHOULD ALWAYS BE FEED FROM THE BOTTOM BY CAPILLARY ACTION OF THE WASTE. BUT IF THE WASTE, AT THE JOURNAL WINDOW, IS DRY FROM LOW OIL LEVELS AND THE TRAM IS TO GO INTO SERVICE IMMEDIATELY AFTER OILING THE BEARING. IT MAY BE NECESSARY TO POUR SOME OIL ON TOP OF THE WASTE.***

***DRY WASTE MUST NEVER BE USED IN PACKING A BOX.*** Wool waste that is to be used is soaked in oil for some time before it is ready for packing.

### **7.2 Waste Saturation.**

The process is:

- a) Loosen the waste and shake out thoroughly before placing it in a saturating vat. Completely submerged the waste in oil at a temperature of not less than 21° C (*70° F*) for a period of not less than 48 hours to ensure the thorough soaking of the threads. 1 kg of dry waste, when it is properly soaked should weigh 3 kg. This is often referred to as the two-in-one ratio.
- b) Drain on a rack (chicken wire or hardware cloth are good) for the purpose of removing the excess oil, until the packing is in a resilient or elastic condition. Oil should not drip from the

## SYDNEY TRAMWAY MUSEUM

drained packing when it is lifted from the drain rack, but oil should flow from it when it is squeezed with the hand.

In observing waste storage and use in practice, the author has observed that it is usually left submerged all the time while in storage and drained only just prior to using.

### **7.3 Journal Bearing Packing (Axleboxes).**

Great care shall be taken in journal packing as hot boxes or badly worn bearings can be dangerous as well as very difficult to repair. The Museum has almost no replacement journal brasses on hand and replacement bearings can be manufactured but it is time consuming and costly, so those bearings in use on the tramcars must be looked after properly and carefully.

Poor lubrication can cause difficulty. Poor lubrication may mean poor oil or not enough oil. Only use the best possible grade of oil as its cost is small in relation to that of the journal replacement.

Poor oiling may be caused by the following conditions:

- a) The waste may not be up against the journal (especially if anything but 100% wool waste is used). Use a packing iron to tease the waste up.
- b) The waste may not have sufficient capillary power (if the wrong grade or wet waste is used) or may be charred or glazed, or the oil may have been washed out by water getting into the box.

Other causes of poor bearing lubrication and excessive wear are:

- a) Too much pressure at the bearing caused by too small a part of the bearing resting on the journal of the axle. The bearing might be raised off from the journal by small pieces of grit, sand, or a small piece of waste. *SOLUTION*: - Jack up the tram, remove the brass and wipe off the journal and brass with a clean lint free cloth – *don't use waste as a small piece may remain behind*. Inspect the bearing face for any foreign particles embedded in the babbit. If any particles are found, they are to be removed carefully as not to damage the surface and the surface is to be carefully scraped to a smooth finish. Apply oil all over the journal and brass with an oil can and replace the journal brass.
- b) The bearing may also be out of line as is the case when the trucks are not square or when there is too much play in the pedestals or shackle pins. (*SOLUTION* – check the shims or pins or bushes). When too much play exists, the brakes push the axle to one side so that only a small part of the bearing carries the load. This causes the bearing to wear tapered.
- c) Too much pressure on the bearing is also caused by the bearing being too tight on the sides or ends causing a pinching of the journal - when newly installed. Sometimes a bearing is too large. This means that the load is carried on a small surface at the centre of the bearing only. Some journals are worn down quite a bit. These require special bearings to be made or a new axle to be installed. Great care must be taken in replacing bearings that one too large or too small is not used. Indiscriminate switching of brasses should NOT be done.

Below are some of the causes of hot boxes; of which the major cause is – *excessive friction* – caused by:

- a) Defective Lubrication caused by:
  - Poor lubricant;
  - Not enough lubricant which could be caused by:
    - i. Waste getting under the journal bearing;
    - ii. Waste not against the journal;
    - iii. Not enough waste in the journal box;
    - iv. Waste with poor lifting power;
    - v. Waste not springy;
    - vi. Oil washed out by water;

## SYDNEY TRAMWAY MUSEUM

- vii. Waste charred;
  - viii. Waste not properly saturated with oil;
  - ix. Waste which is saturated with a mixture of oil and water; and
  - x. Short strand waste.
- b) Excessive Bearing Pressure caused by:
- Not enough bearing area caused by:
    - i. Too small journal;
    - ii. Bearing out of alignment;
    - iii. Presence of grit, sand and dust; and
    - iv. Bearing too tight or too loose.
  - Poor bearing metal
    - i. rough bearing casting.

### **7.4 Dust Cap.**

In order to hold the waste in place, a small piece of waste should be placed in front of the box as shown in *Figure 1*. This end piece of waste is usually referred to as a dust cap and gives no lubrication to the bearing. It does collect dust and dirt that gets in from the cover and should always be removed when the waste is added to the box. Too many careless oilers push this dust cap in under the journal when the waste has worked away from the journal and then put in a new dust cap. This practice is bad and causes grit to get into the journal. The top of the dust cap should not reach above the lower edge of the cover opening. Twelve (12) mm (*half-inch*) below the cover is good practice. No loose strands should be left hanging out for there is a tendency for the oil to be siphoned out, and also the cover will not seat tightly.

### **7.5 Journal Box Inspection.**

When oil is added it should be applied along the sides of the waste or into the oil well.

Journal boxes should be inspected weekly for operating equipment as follows:

- a) See that the packing is in suitable condition. If the packing iron goes through the waste, the waste is soggy and should be removed and all water soaked out of the box;
- b) The waste must be kept below the centre line of the journal;
- c) The waste should be “teased” to the back of the box and in the event of shortage of waste, the dust cap should be removed and the new waste added in the form of loose twisted wicks; and
- d) Oil may be added if there is a sign of lack of oil, but applying oil to every box whether it needs it or not, is poor inspection.

### **7.6 Packing the Journal Box.**

When packing the journal box, perform the following:

- a) When inspecting or packing journal bearings, close attention should be given to the dust guard at the rear end of the journal box. It must be in first class condition and fit as closely to the axle as possible. A new dust guard should be placed in the journal box and made to fit so that it slides freely in the slot and that there is clearance at the sides of the slot so that the guard will not be crushed when the truck goes around a curve. The hole in the guard should not be more than 2 mm (*1/16 inch*) larger in diameter than the diameter of the dust guard seat on the axle. The appropriate thickness of exterior (marine) plywood can be used for this job although original type timber should be used to maintain originality;
- b) Make a good sized rope from the packing and place it tightly at the rear end of the box, allowing the ends to come well around the axle to exclude dust and dirt and to avoid the waste of oil;

## SYDNEY TRAMWAY MUSEUM

- c) The remainder of the box under the journal is to be packed with loosely formed saturated packing, packed firmly, but not tight and the waste should not extend above the centre line of the bearing and should end inside the button (collar) on the end of the axle; and
- d) Fill the remaining space in the end of the box with the dust cap – also not allowing it to come above the centre line of the axle.

End Elevation

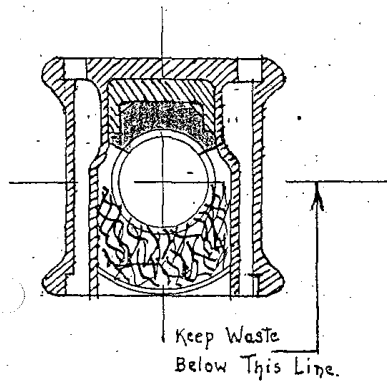

Side Elevation

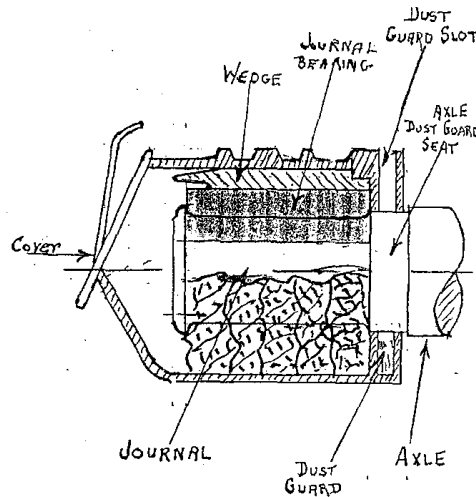

*Figure 1*

### **7.7 Tools Necessary for Packing Axle Boxes.**

The following tools are required:

- a) Wire Brush – for cleaning the covers before opening;
- b) Flash light - for examining oil levels;
- c) Oil Level Gauge – 9 to 12 mm ( $\frac{3}{8}$  to  $\frac{1}{2}$  inch) metal rod marked in centimetres, about 300 mm (12 inch) long;
- d) Waste hooks – long and short – for removing old waste;



- e) Packing Irons – Long and short – for packing in waste and made of brass or some other soft metal to prevent damage to the journals;

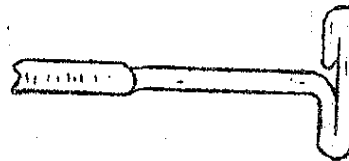
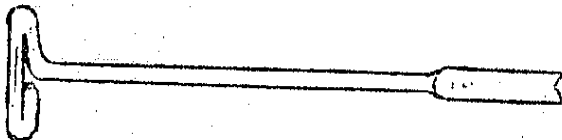

- f) Half-cup measure – for checking and recording the amount of oil added;
- g) Pan – to lay old waste in to keep the waste out of the dirt; and
- h) Bucket – non-galvanised – for new waste (galvanised buckets are apt to react with the acid in the oil).

## **8. AXLE COLLARS.**

### **8.1 Packing and Inspection.**

Before the bearings are packed, all water, dirt, and small particles of metal should be removed from the oil well. In packing, use a pronged rod of brass, or some other soft metal which will not injure the journal.

Place the waste (properly saturated) in the journal box in large bunches. If small bunches are used, a continuous path for oil to rise is not provided. When the opening in the journal box is small, long bunches should be used. The journal box must be packed tightly and the entire journal box filled. The entire bearing window must be filled with waste. There is, of course, such a thing as packing too tight, but packing too loose is worse. When the packing is completed, the waste chamber should be full to the top with just enough space left to close the cover tightly.

### **8.2 Motor Axle Suspension Caps (Keeps) and Bearings.**

Excessive wear on axle suspension bearings is not as serious as on Armature Bearings as it only subjects the frame axle cap and axle cap bolts to increased shocks and strains and tends to spread the gear centres, with resulting less efficient gear operation and rapid wear. The wear limits for axle suspension bearings have not been definitely set, but when the radial wear for an axle bearing is 3 mm (*1/8 inch*), or when a 3 mm (*1/8 inch*) piece of solder can be placed between the axle bearing and the axle, the bearing should be replaced.

This wear can readily be checked with feeler gauge (such as a piece of solder) from the pit. If necessary, remove the axle shield (between the two (2) bearing caps) to make the inspection.

DO NOT use shims in the back of the bearing to make a tight fit in the motor frame.

The following points should be noted when replacing axle bearings:

- a) Bearing shells should preferably be made from bronze and not Babbitt lined or tinned. (The Babbitt will only chip and break out in a split bearing).
- b) Chamfer all bearings at the window to remove the sharp edge which would have the effect of scraping the lubricant off before it could get under the bearing. Chamfer at the halves for the same reason.
- c) Oil grooves are not required.
- d) New axle bearings should be brought from the original motor manufacturers (where possible) and finished bored to size. Some of them should be rough bored undersize to allow ample metal to fit new bearings to worm axles.
- e) Allowances and variations should be made as follows:

<u>Nominal Bore</u>	<u>Allowances &amp; Variations</u>
Up to and including 127mm ( <i>5 inch</i> )	Plus 381( <i>0.015 inch</i> ) to plus 432 microns ( <i>0.017 inch</i> )
Over 127 mm ( <i>5 inch</i> ).....	Plus 711 ( <i>0.028 inch</i> ) to plus 762 microns ( <i>0.030inch</i> )
- f) Keep bearings from working loose by maintaining the dowles or keys tight and in good condition,
- g) The outside of all shells should be given an allowance of plus 0 micron to plus 76 microns (*0.000 inch to plus 0.003 inch*).
- h) Bearing shells should be a tight clamping fit in the motor frame and axle (keep) cap.

## SYDNEY TRAMWAY MUSEUM

- i) DO NOT MIX AXLE CAPS UP ON THE VARIOUS MOTOR FRAMES. Whenever possible, use the ones as furnished with the motor frame originally.
- j) Carefully clean all of the surfaces of the housings, axle caps and frames at the fit when assembling.
- k) **Heat treated high grade special bolts** should be used to hold these parts in place. Use only lock washers.

### **8.3 Removing Axle (Suspension) Bearing.**

In case it becomes necessary to remove the axle bearings while the motor is on the truck, proceed as follows:

- a) Run the tram over the pit if one is available. If not, locate it to the best advantage for working on the underside of the axle;
- b) Remove the axle dust shield from between the axle bearings by taking out the four tap bolts which hold it in place;
- c) If the bearing being removed is on the gear side, it will be necessary to take out the two (2) gear case bolts and drop the lower half of the gear case; and
- d) Take out the four (4) axle bearing cap bolts and remove the cap. If the cap sticks, it can be loosened by tapping a flat cold chisel in the crack between the cap and the motor frame, first on one side and then on the other. Care should be taken to see that the cap is properly supported by a helper or backed up by blocking when it is being loosened in order to prevent personal injury. The lower half of the axle bearing will drop down with the cap and can readily be knocked out with a hammer. To remove the upper half of the bearing, jack up under the motor frame a sufficient amount to relieve the weight on the bearing. Then revolve the upper half around the axle until it can be slipped off below. If the bearing sticks in the frame, it can be knocked loose by driving down on the flange with a hammer and a wooden block.

### **8.4 Hot Axle (Suspension) Bearing.**

Hot axle (suspension) bearings can be caused by any one of the following causes:

- a) Lack of oil in bearings;
- b) Imperfectly packed bearings;
- c) Grit or foreign matter working into bearings;
- d) New bearings with insufficient clearances;
- e) Motor nose clamped; and
- f) Excessive play in truck axles.

The strap holding the motor nose should not be applied in such a way that it produces a clamping action, as severe stress on the nose and suspension bearings may be produced.

Motor axle Suspension Boxes have to be repacked seldom, but careful inspection is required just the same. When a suspension box has been packed and is inspected, the cover is opened. All dirt should be removed from the cover so that none will drop into the suspension box. The dust cap is then removed and the waste teased up to the window. If more waste is needed it should be added and the dust cap replaced. It is considered good practice to repack the bearings every three (3) months for trams in heavy service, at this time removing all the waste, discarding all waste which has been glazed and charred and refilling the bearings with clean old waste to which has been added sufficient new waste. ***About once every three (3) month it is advisable to tease up the waste in the bearings to make it more effective.***

## SYDNEY TRAMWAY MUSEUM

Axle boxes that have no oil tubes must be checked at each inspection for oil levels. Oil level must be brought up to the maximum height at each inspection. A minimum height oil level is also to be watched, If the oil level gets below the minimum level, it is generally necessary to add some oil to the waste as near to the window as is possible.

If the oil levels are too high, oil will have a tendency to run out of the window and be wasted. Twelve (12) mm ( $\frac{1}{2}$  inch) below the lower opening of the window is a good maximum oil level to be maintained. Some boxes have very small oil tubes and very little oil can be stored. The new design provides for a separate oil tube and a large capacity oil reservoir. This new design also makes possible maintenance of more constant oil levels and longer periods between inspections. Unfortunately most of the trams in the Museum fleet, in regular service are not equipped with this type of oil box.

Well designed bearings of this type (ideally and when new) if in good condition and properly packed should run from one to three weeks between oilings. When inspecting bearings, all dirt should be carefully wiped from the oil box lid, after which the proper amount of oil should be poured into the **OIL WELL OPENING, NOT ON THE WASTE** if there is one provided.

Quarter of one litre ( $\frac{1}{2}$  a pint) of oil per bearing should be required at each inspection period.

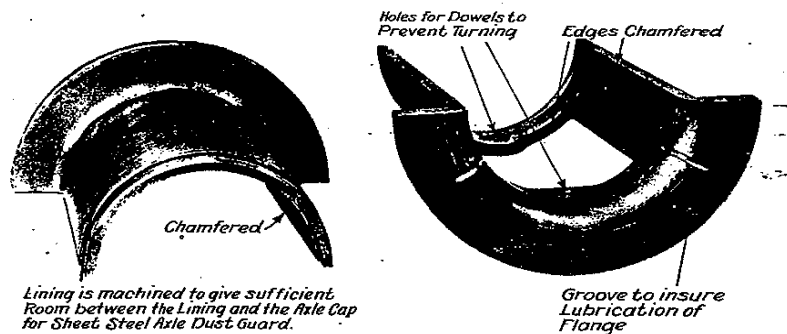

*AXLE SUSPENSION BEARINGS*

# SYDNEY TRAMWAY MUSEUM

## MOTOR AXLE SUSPENSION BEARING.

Window Half.

Plain Half.

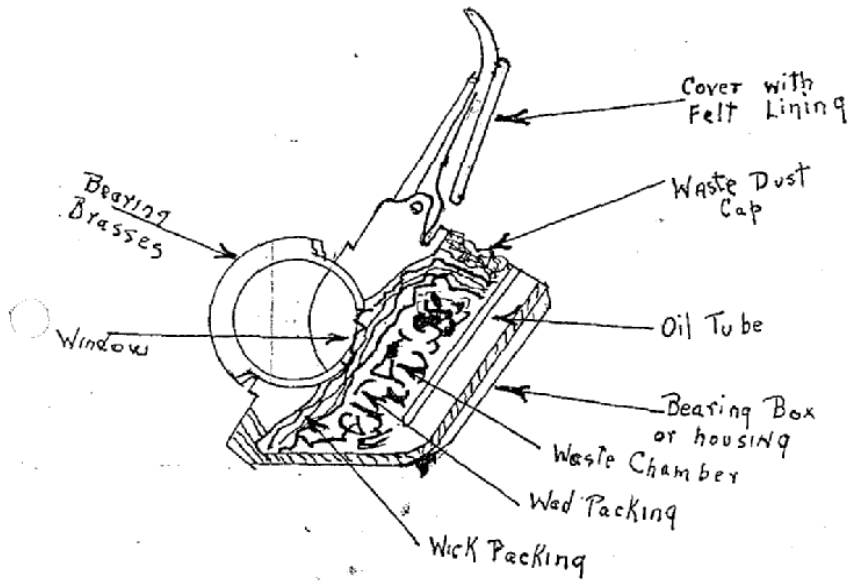
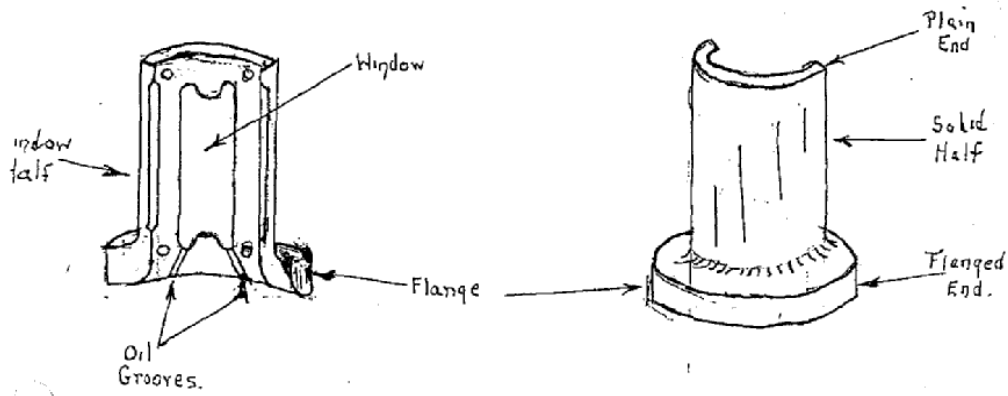

## MOTOR AXLE SUSPENSION BEARING.

Figure 2

## SYDNEY TRAMWAY MUSEUM

### 8.5 Armature Bearings.

From the diagram of the Armature Bearing (*Figure 3*), it can be seen that too much oil on the armature bearings will rise above the bearing window and overflow into the motor. This is likely to injure the insulation and is further a waste of the oil. On the *average*, the maximum height of oil in the armature bearings for a 37.3 kilowatts (*50 horsepower*) motor (e.g. a GE 216 motor) should be about 89 mm (*3.5 inches*) while the minimum should be about 25 mm (*1 inch*). For axle bearings the maximum should be 64 mm (*2-½ inches*) and the minimum about 38 mm (*1-½ inches*). These heights can be checked by a rod placed in the oil well.

### 8.6 Water in Bearings.

The presence of water in bearing boxes is probably the most common cause of rapid bearing wear and bearing failure. This trouble can be reduced or even prevented by a careful periodic inspection of the axle and armature box covers. At the inspection, dirt which might keep them open should be removed and the spring and seal inspected.

In all cases where a tram has been subjected to an operation in wet weather over an extended period of time, the axle boxes should be inspected to determine if there is water in them. The simplest way to do this is to remove some oil from the bottom of the oil reservoir with a suction gun through the oil tube. If there is no oil in the oil tube, then the waste must be removed and the bottom end of the wick must be squeezed. If there is water in it, it will come out readily.

If there is water present, all of the waste must be removed, all of the oil, water and dirt must be cleaned out and the box repacked with fresh oil-soaked waste and oil. The presence of water in the waste will deteriorate the waste rapidly. It loses its capillary action and can no longer take the oil from the reservoir to the bearing where it is needed. This results in ultimate failure of the bearing.

The diagram illustrated in *Figure 3* shows a typical armature box. The window of the bearing opens into the box usually in the manner shown in the diagram. One exception to this is the GE 80 motor where the window opens at the top. The GE80 motor armature bearing is called a top-feed bearing, whereas the armature bearing illustrated is a side feed bearing. The GE 80 motor bearing is necessarily top-feed design because the motor has a split frame.

## 9. AXLE COLLARS.

The function of an axle collar is to keep the motor properly located sidewise on the axle so that the centre of the pinion on the motor shaft will line up with the centre line of the gear on the tram axle. Some collars have one adjusting bolt, others have two. The head of the adjusting bolt backs up against the wheel hub, and can be adjusted whenever the flange of the axle bearing wears so as to cause excessive side play. The axle collar should be adjusted whenever the end play on the tram axle is greater than 6 mm (*¼ inch*). The adjusting bolts and clamping bolts must always be held in place with lock washers. The adjusting bolt, in addition to the lock washer has a cotter key which prevents the adjusting bolt from turning out in position.

The face of all collars should be given a smooth slick finish to minimise friction and wear. The maximum value for the end play on motors up to 37.3 kilowatts (*50 horsepower*) should be 6 mm (*¼ inch*), and above 37.3 kilowatts (*50 horsepower*) is 9 mm (*⅜ inch*).

# SYDNEY TRAMWAY MUSEUM

## MOTOR ARMATURE BEARINGS-

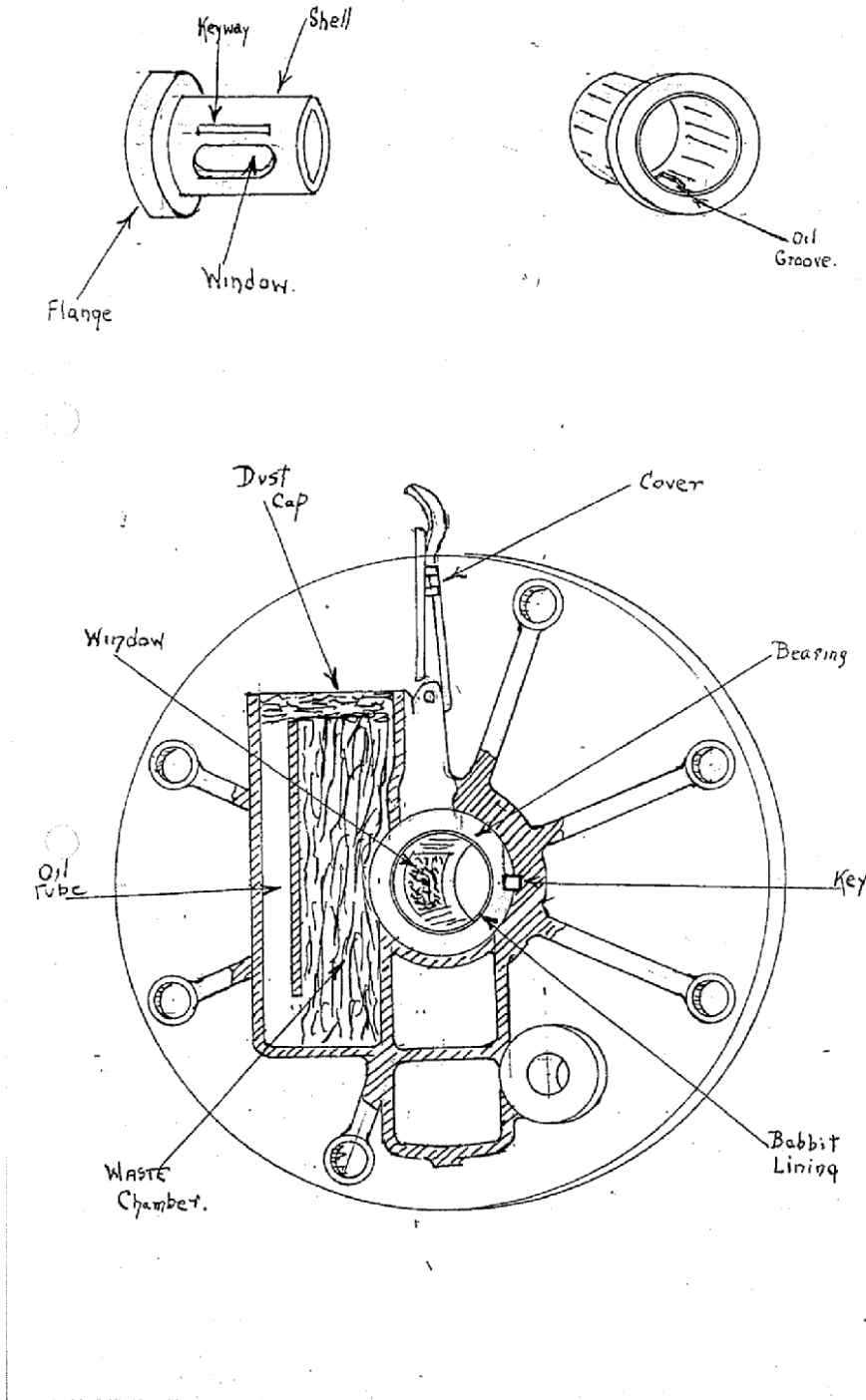

Figure 3

# SYDNEY TRAMWAY MUSEUM

## RECOMMENDED OIL LEVELS

<u>Motor</u>		<u>Armature Bearing Oil Well</u>				<u>Axle Bearing Oil Well</u>				KGS Lbs 2:1  Waste
Type	K.W.  (H.P.)	Pinion End		Commutator End		Pinion End		Commutator End		
		Max.	Min	Max.	Min	Max.	Min	Max.	Min	
70	30 (40)	64 mm <i>2-½ inch</i>		64 mm <i>2-½ inch</i>			No oil tube			2.50 <i>5-½</i>
74	56 (75)						No oil tube			3.18 <i>7</i>
80	30 (40)	Top Feed Design					No oil tube			2.50 <i>5-½</i>
200		64 mm <i>2-½ inch</i>		51 mm <i>2 inch</i>		83 mm <i>3-¼ inch</i>		83 mm <i>3-¼ inch</i>		
202		95 mm <i>3-¾ inch</i>	51 mm <i>2 inch</i>	64 mm <i>2-½ inch</i>	25 mm <i>1 inch</i>	76 mm <i>3 inch</i>	38 mm <i>1-½ inch</i>	76 mm <i>3 inch</i>	38 mm <i>1-½ inch</i>	
203		89 mm <i>3-½ inch</i>	51 mm <i>2 inch</i>	64 mm <i>2-½ inch</i>	25 mm <i>1 inch</i>	64 mm <i>2-½ inch</i>	25 mm <i>1 inch</i>	64 mm <i>2-½ inch</i>	25 mm <i>1 inch</i>	
205	75 (100)	102 mm <i>4 inch</i>		89 mm <i>3-½ inch</i>			No oil tube			4.31 <i>9-½</i>
207	108 (145)						No oil tube			4.31 <i>9-½</i>
216	37 (50)						No oil tube			2.50 <i>5-½</i>
226		89 mm <i>3-½ inch</i>		64 mm <i>2-½ inch</i>		76 mm <i>3 inch</i>		76 mm <i>3 inch</i>		
247	30 (40)	79 mm <i>3-⅞ inch</i>	38 mm <i>1-½ inch</i>	79 mm <i>3-⅞ inch</i>	38 mm <i>1-½ inch</i>	64 mm <i>2-½ inch</i>	25 mm <i>1 inch</i>	64 mm <i>2-½ inch</i>	25 mm <i>1 inch</i>	1.36 <i>3</i>
251		102 mm <i>4 inch</i>		89 mm <i>3-½ inch</i>						
254	101 (135)	89 mm <i>3-½ inch</i>	38 mm <i>1-½ inch</i>	76 mm <i>3 inch</i>	25 mm <i>1 inch</i>	51 mm <i>2 inch</i>	25 mm <i>1 inch</i>	76 mm <i>3 inch</i>	25 mm <i>1 inch</i>	3.63 <i>8</i>
258	19 (25)					64 mm <i>2-½ inch</i>	25 mm <i>1 inch</i>	64 mm <i>2-½ inch</i>	25 mm <i>1 inch</i>	
264	19 (25)	86 mm <i>3-⅜ inch</i>	38 mm <i>1-½ inch</i>	64 mm <i>2-½ inch</i>	25 mm <i>1 inch</i>	64 mm <i>2-½ inch</i>	25 mm <i>1 inch</i>	64 mm <i>2-½ inch</i>	25 mm <i>1 inch</i>	0.91 <i>2</i>
265	26 (35)	83 mm <i>3-¼ inch</i>	38 mm <i>1-½ inch</i>	73 mm <i>2-⅞ inch</i>	25 mm <i>1 inch</i>	76 mm <i>3 inch</i>	25 mm <i>1 inch</i>	76 mm <i>3 inch</i>	25 mm <i>1 inch</i>	
275		86 mm <i>3-⅜ inch</i>	38 mm <i>1-½ inch</i>	64 mm <i>2-½ inch</i>	25 mm <i>1 inch</i>	114 mm <i>4-½ inch</i>	64 mm <i>2-½ inch</i>	114 mm <i>4-½ inch</i>	64 mm <i>2-½ inch</i>	

## 10. AIR COMPRESSORS

### 10.1 Maintenance of Air Compressors.

All of the Museum's compressors use the "splash" system for lubricating the connecting rod bearings. On most of the compressors, the gears and pinions are lubricated by having the gear partly submerged in oil. The motor bearings are lubricated either by the "splash" system or by oil rings.

Before adding oil, wipe off all dirt around the oil hole to prevent dirt from falling into the oil well. Be sure to turn the air compressor switch to "OFF" before adding oil.

Best results are obtained when the oil level is not allowed to fall more than 8mm ( $\frac{1}{4}$  inch) below the maximum level as determined by the oil fittings.

Dirty oil should be drained from the compressor at periods of from 6 to 18 months depending upon the service of the tram. The interior of the compressor should be thoroughly cleaned with petrol, draining the petrol thoroughly before replacing the compressor with fresh oil.

If the oil is added while the compressor is running and the wells are filled to overflow, there will be too much oil in the well when the compressor stops and the oil level will be above the overflow hole. A compressor should not use more than 0.57 Litre (*1 pint*) of oil between inspections.

### 10.2 Overhaul of Air Compressors.

Compressors are to be serviced between 12 to 18 month intervals during regular service.

Field coils and armatures should be given a good petrol bath, followed by a thorough drying out and a liberal application of varnish and shellac. Bearings should be maintained to prevent noisy operation particularly on the connecting rods. Valve and valve heads must be thoroughly cleaned. The suction strainer must be kept clean; otherwise dirt will be drawn into the compressor and the efficiency of the compressor greatly reduced. Clean the components with petrol.

The compressor should be entirely dismantled and thoroughly cleaned out with petrol. Particular attention should be given to all wearing parts and proper adjustments made to eliminate lost motion due to wear. It is important that the rings and ring grooves be cleaned and that the rings have a good bearing on the cylinder wall and the grooves.

On an inspection the following should be done:

- a) Blow out the compressor with compressed air – avoid damage by using only low pressure;
- b) Wipe off brush holders, insulators, commutator front V-ring band, and the inside of the cover;
- c) See that the wires connected to the brush holders are secure;
- d) Take hold of the brush holders and see that they are secure;
- e) See that the brush holder is not more than 3 mm ( $\frac{1}{8}$  inch), or less than 2 mm ( $\frac{1}{16}$  inch) from the commutator surface;
- f) Remove and check the brushes to see that they are free from cracks and chips;
- g) Replace brushes with trade marks facing each other. See that the brushes are long enough to last until the next inspection. See that the hammers exert between 0.9 grams (*2 lbs*) and 1.36 grams (*3 lbs*) pressure on the brushes;
- h) Check the fuse to see that only a 10 amp. fuse is used with DH16 and CP27 type of compressors.

# SYDNEY TRAMWAY MUSEUM

## **10.3 Maintenance of Westinghouse “DH” Type Compressors.**

On an inspection the following should be done:

- a) The air gap should be checked at intervals in order to preclude any possibility of bearings wearing sufficiently to permit the motor to get down on the field and damage or perhaps destroy the windings;
- b) When brushes are changed, they should be ground to a bearing by using a strip of sandpaper on the commutator under the brushes with the sand side towards the brush until the full bearing is obtained. This will prevent excessive sparking which would result from an improper brush bearing, and thus preserve the commutator glaze;
- c) If pounding develops in the compressor, take off the crankcase cover, examine the connecting rod caps where lost motion is most likely to occur and remove the necessary liners to take up wear in the bearing. Never leave an unfilled gap between the cap and the rod, as in that case the bearing may bind on the crank pin. Be sure to tighten the lock nuts and replace the cotter pins;
- d) The best results are obtained with lifts of the valves 4 mm (*5/32 inch*) for the inlet valves, and 3 mm (*1/8 inch*) for the discharge valves on the DH20 compressor;
- e) If the compressor blows its fuse frequently, and the motor is found to be in good order, it may be assumed that the compressor is not working freely. It should be examined for stuck valves, hot bearings, or tight pistons and the trouble remedied.

## **10.4 Maintenance of General Electric “CP” Type Compressors.**

### **10.4.1 Oil Level**

Normally 3 mm (*1/8 inch*) below the top of the filling elbow. Add oil if the oil level is more when 10 mm (*3/8 inch*) below the top of the elbow.

### **10.4.2 Vent Pipe**

In the bottom of the compressor between the motor and compressor is a vent pipe safety drain. An accumulation of oil around this is an indication that the vent pipe requires immediate attention. Remove for cleaning with a socket wrench. When replacing, dope the threads well. The condition of the vent pipe can be determined by holding the hand under it. If there is no sign of air coming from the vent pipe, it is probably clogged with dirt, but if light puffs of air come from it, it is clear. If the vent pipe is clogged, oil from the armature bearing cannot return to the crank chamber as it should, but will be discharged through the safety drain, and be wasted.

If it is found clogged, the 12 mm (*1/2 inch*) pipe plug at the bottom of the oil return should be removed and the oil return passage thoroughly cleaned. The 18 mm (*3/4 inch*) pipe plug at the bottom of the settling well should be removed and any sediment which may have collected drawn off once a year or more often.

### **10.4.3 Cleaning**

Clean the intake strainer as often as necessary.

The motor frame head should be removed and the outer end of the motor, including the brush holders, field coils and motor frame head, should be thoroughly wiped out. If compressed air is used to blow out the motor, a bent nozzle should be used so that the dirt will be blown away from the open end of the motor, not back towards the interior. The use of compressed air at high pressures should be avoided especially when cleaning old compressor motors as it is possible to damage the insulation by this practice.

## SYDNEY TRAMWAY MUSEUM

### 10.4.4 Brush Holders

<u>Spring Tension</u>	<u>Kgs/Sq cm Pressure</u>	<u>lbs/Sq inch Pressure</u>
CP – 25	0.12 to 0.16	1- <sup>3</sup> / <sub>4</sub> to 2- <sup>1</sup> / <sub>4</sub> lbs
CP – 27	0.18 to 0.21	2- <sup>1</sup> / <sub>2</sub> to 3 lbs
CP – 30	0.21 to 0.25	3 to 3- <sup>1</sup> / <sub>2</sub> lbs

### 10.5 Brake Piston Travel.

The movement of the piston in and out of the brake cylinder is called piston travel, but the correct meaning of piston travel is the “*distance, in millimetres (inches), that the piston moves from release to brakes fully applied*” in a service application.

With the straight air-brake, the pressure in the brake cylinder should equal the governor cut-out pressure when the piston travel is measured. The piston travel measured when the tram is in motion is more than the travel when the tram is stationary. The jarring of the tram in motion reduces the friction between the pins in the brake rigging and the tram axles and journal bearings. Running piston travel is usually from 12 mm to 25 mm (*½ to 1 inch*) greater than standing piston travel.

**BRAKE SHOE CLEARANCE OF 3 mm (*1/8 inch*) USUALLY REQUIRES 100 mm (*4 inches*) OF PISTON TRAVEL.**

## 11. OTHER EQUIPMENT

### 11.1 Trolley Bases and Trolley Wheels and Shoes

Trolley bases should be taken apart at overhaul inspections, repaired, cleaned out and greased. Graphite grease is usually applied to the roller type bases and oil for bush type bases, after the base has been cleaned with solvent. At the light inspection, compressor oil should be used to lubricate bush type trolley bases through the oil hole. Greased bases usually need very little attention, but occasionally a little grease needs to be pumped into the base through the grease nipple on top of the base.

Trolley shoes are usually oiled by placing a few drops of compressor oil between the shoe and the harp. This goes for some designs of trolley wheels too, all though Sydney trolley wheels are graphite lubricated via the three contact brushes in the axle.

### 11.2 Trolley Catches and Retrievers

Ohio Brass – as fitted to PCC 1014 – remove the plug in the centre of the outside case and fill with compressor oil.

When new springs are installed they should be sprayed with compressor oil to prevent rusting.

### 11.3 Trolley Ropes

The standard Sydney trolley rope is No. XX type sash cord and is cut to specific lengths for various classes of cars (see Maintenance Manual). The trolley rope is usually boiled in wax; the excess wax is wiped off and hung to cool. This is to stop premature aging of the rope and to keep the rope dry in service. See the Maintenance Manual for the correct method of attaching the rope to the trolley harp and the tramcar.

### 11.4 Gates and Ploughs

Gates and ploughs are in use for safety reasons as they were used in normal service and they shall not be tied up. The hinge points and pins should be well oiled with drained (sump) oil or some other cheap lubricant.

# SYDNEY TRAMWAY MUSEUM

## **11.5 Brake Rigging and Cylinders**

After the brake cylinder has been disassembled and cleaned, apply a thin coating of cylinder lubricant to the wall of the cylinder with a brush. Fill the expander ring groove at the same time, coating the inside of the leather and place the expander ring in position.

Brake rigging rods and levers that slide over guides are greased with Gear Case Grease. An old paint brush makes a good swab for applying the lubricant, while the brakes are released. Slack adjusters should be lubricated with Alvania EP grease using an alemite gun whenever possible. All other joints and swing links are oiled with drained (sump) oil from the air compressor.

Make sure the hand brakes works freely. Oil the hand brake shafts and gear wheel bearings with drained (sump) oil from the air compressor.

## **11.6 Truck Centre and Side Bearings**

Centre bearings are equipped with bronze wear plates and may have grease nipples fitted, more often they do not. If the tramcar does not have a grease nipple, the tramcar will need to be lifted off its trucks by about 25 to 50 mm (*between 1 to 2 inches*) and grease applied with a grease gun **NOT FINGERS**, the movement of the tramcar will finish spreading it for you. Some wear plate centre bearings and rubbing plates have oil tubes that project from the bearing face and in these cases, bearing oil should be used to fill their oil wells. Rubbing plates that consist of two wear plates that slide over each other are swabbed with centre bearing grease while the car is lifted from the truck.

## **11.7 Truck Wear Plates and Pedestals**

These parts are swabbed with centre bearing grease while the car body is lifted from the truck.

## **11.8 Draw Bars, Couplers and Sway Bars**

The sway bars that guide the draw bars and couplers should be swabbed with centre plate grease at each lubrication inspection.

For a sample type of lubrication inspection sheet which should be used in checking the lubrication of our cars, see Appendix A.

**NOTE:** Drained (sump) oil as referred to in the above lubrication descriptions is the oil that has been drained from air compressors not from motor vehicle engines. As motor vehicle sump oil has become high in carbon and acidic compounds and is a very thin oil i.e., very little lubrication properties.

ooo000ooo



# SYDNEY TRAMWAY MUSEUM

## LUBRICATION MATERIAL

ITEM	Shell Corena Oil	Shell Omela 460	Mobile Gear 634	Petroleum Jelly	Caltex TMGL Grease	Shell Alvania Grease	Graphite Based Grease	Drained Sump Oil
Air Compressor	✓							
Axle Box Bearing		✓	✓					
Armature Bearings		✓	✓					
Brake Rigging, Rods & Levers - that slides					✓			
Brake Rigging, Rods & Levers – slack adjusters						✓		
Brake Rigging, Rods & Levers – all joints								✓
Coupling Pivots					✓			
Coupling Slide Bars					✓			
Door Hinges and Runners						✓		
Door Motors						✓		
Double Check Valve						✓		
Driver's Brake Valve						✓		
Electrical Equipment				✓				
Emergency Valve						✓		
Gates and Ploughs						✓		✓
Gear Case					✓			
General Lubrication						✓		
Handbrake Mechanism and Rigging								✓
Main Air Brake Rigging				<i>see brake</i>	<i>Rigging</i>	<i>Above</i>		
Motor Suspension		✓	✓					
Relay Valve						✓		
Seat Mechanisms						✓		
Traction Gears					✓			
Trolley Catcher	✓							
Trolley Pole Base							✓	
Trolley Shoes	✓							
Trolley Wheels	✓						✓	
Truck Centre Bearing		✓	✓					
Truck Wear Plates and Pedestals		✓	✓					

*NB - Drained (sump) oil as referred to above is the oil that has been drained from air compressors not from motor vehicle engines*